

ALL DIMENSIONS IN mm

FRACTIONAL TOLERANCE: ±2mm  
ANGULAR TOLERANCE: ±1°

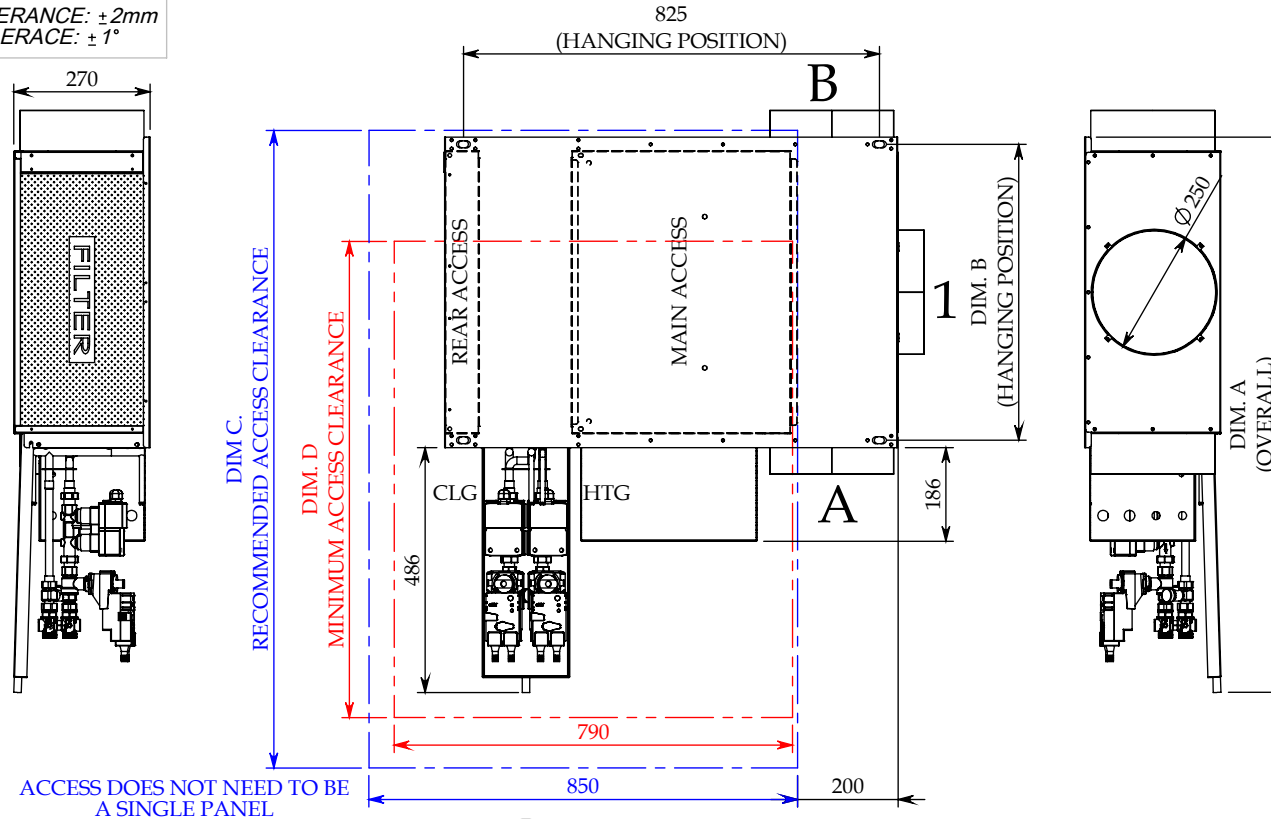

ACCESS DOES NOT NEED TO BE A SINGLE PANEL

FCU SIZE	DIM. A	DIM. B	DIM. C	DIM. D
MODEL 100	1102	587	1265	945
MODEL 200 / 250	1402	887	1565	1245
MODEL 300 / 350	1702	1187	1865	1545
MODEL 400	2002	1487	2165	1845
MODEL 500 / 550	2302	1787	2465	2145
MODEL 600 / 650	2602	2087	2765	2445

FCU SIZE	MAIN ACCESS PANEL SIZE		
MODEL 100	561	x	436
MODEL 200 / 250	861	x	436
MODEL 300 / 350	1161	x	436
MODEL 400	1461	x	436
MODEL 500 / 550	1761	x	436
MODEL 600 / 650	2061	x	436

FCU SIZE	REQ'D No. OF DISCHARGE SPIGOTS
MODEL 100	1
MODEL 200	1
MODEL 250	2
MODEL 300	2
MODEL 350	3
MODEL 400	3
MODEL 500	3
MODEL 550	4
MODEL 600	4
MODEL 650	5

**IMPORTANT NOTE:**

HEATING AND COOLING VALVES AND CONNECTIONS ARE REVERSED ON OPPOSITE HANDS OF UNIT

**DETAIL SCALE 1:10**

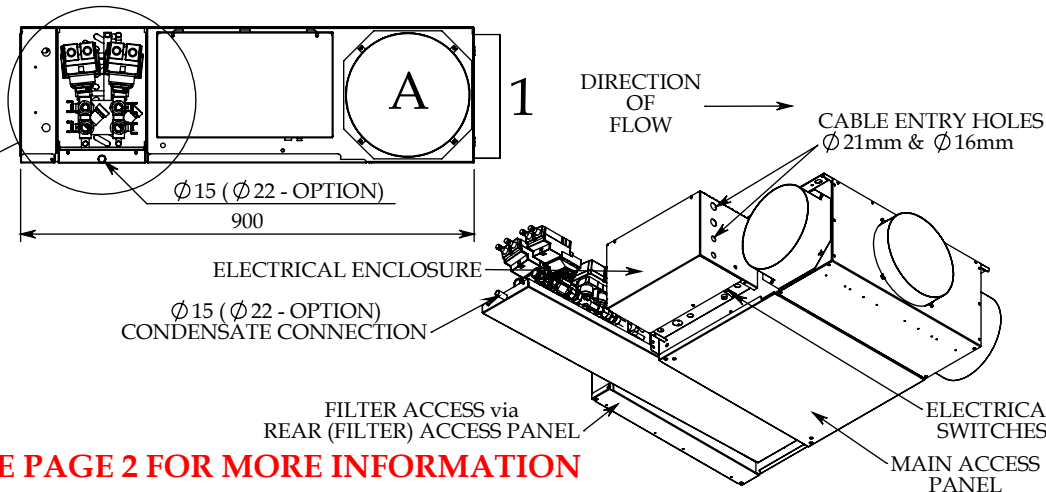
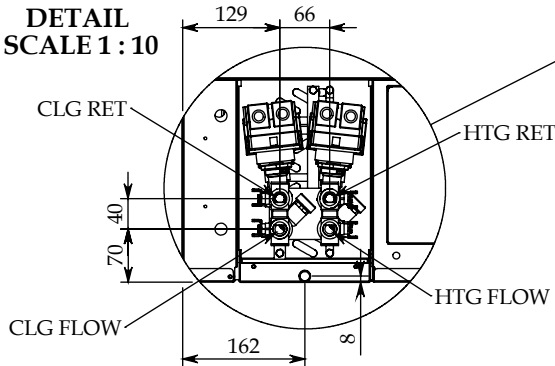

SEE PAGE 2 FOR MORE INFORMATION

GENERAL ARRANGEMENT DWG.  
MAT270 - TROJAN FAN COIL UNIT  
  
LEFT HAND FAN COIL UNIT SHOWN

REV	DESCRIPTION	INIT	DATE
E			
D	Dimension added	AMB	16/01/2018
C	BYPASS ASSEMBLY REVISED	DPB	16/11/2017
B	Model sizes 604 and 605 have been changed to sizes 600 and 650	LWV	03/08/2015
A	VALVE ASSEMBLY REVISED.	PRB	27/01/2015



TITLE  
MAT270 Horizontal Chassis Fan Coil Unit  
Matrix 2.0 / Matrix 3.0 - 250 DIA

DRAWN BY	PRB	DATE	21/03/2014	SCALE 1:15
CHECKED BY	MPA	DATE	21/03/2014	
DRAWING NO.			REV	PAGE
GS0341			D	1 of 3

ALL DIMENSIONS IN mm

FRACTIONAL TOLERANCE:  $\pm 2\text{mm}$   
ANGULAR TOLERANCE:  $\pm 1^\circ$

LEFT HAND FAN COIL UNIT SHOWN

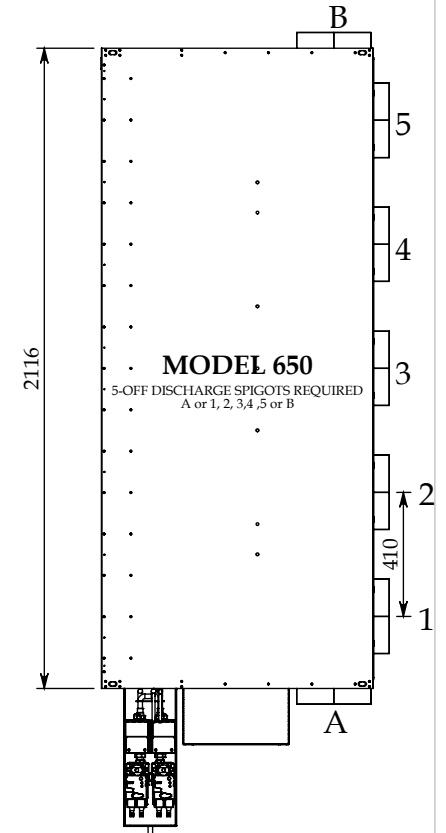
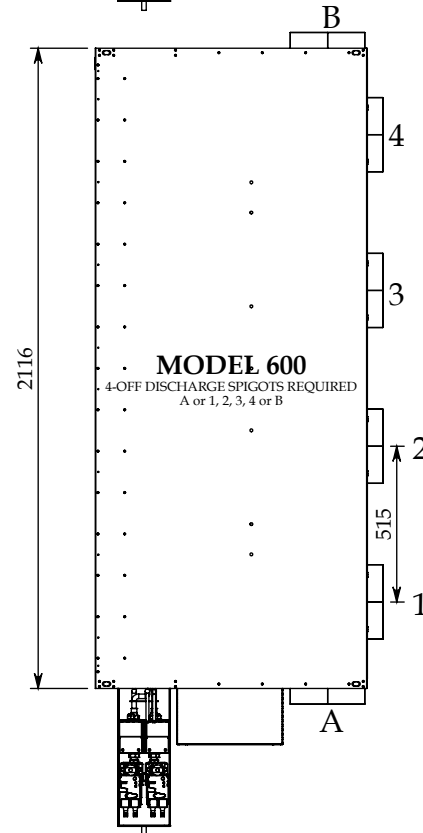
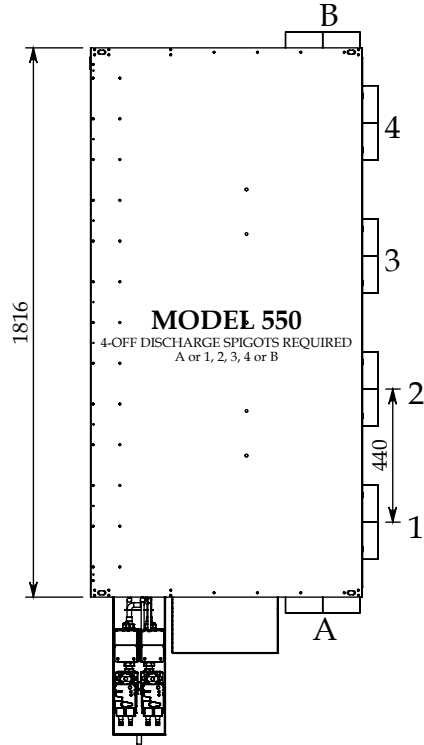
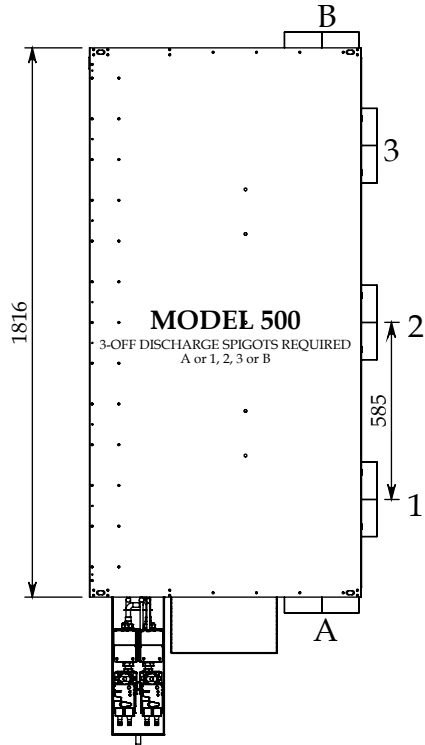
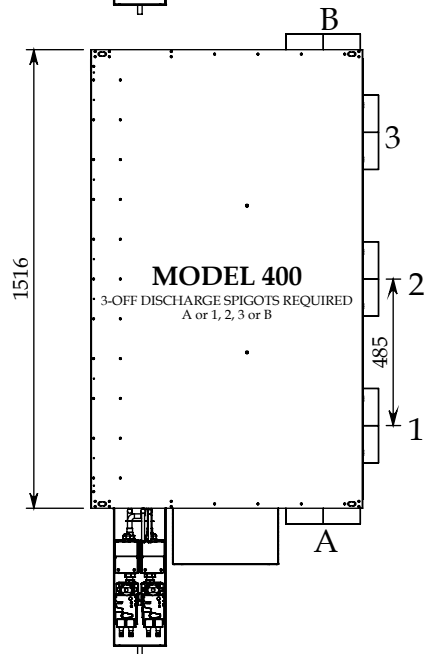
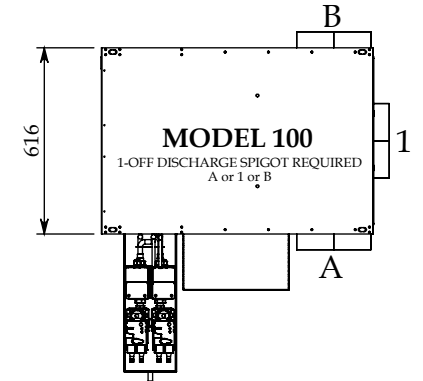
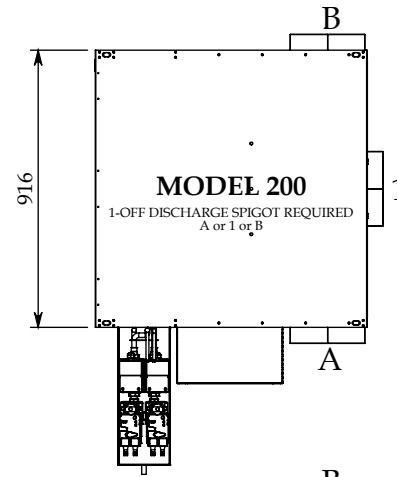
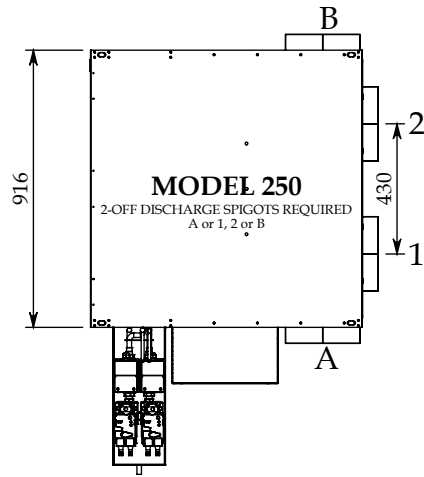
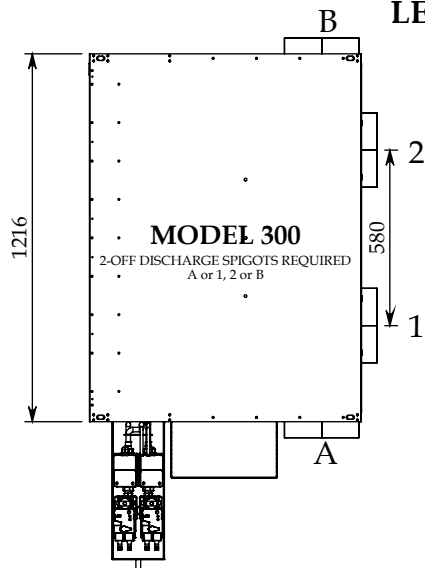
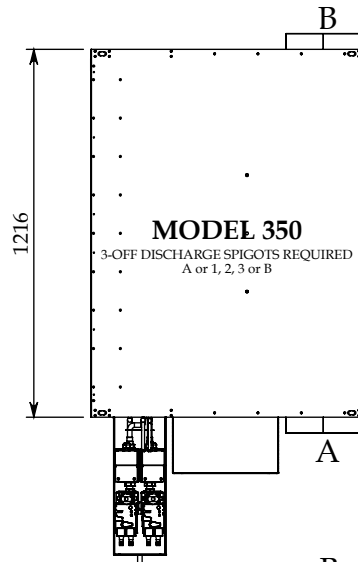

E					DRAWN BY	PRB	DATE	21/03/2014	SCALE 1:25
D	Dimension added	AMB	16/01/2018		CHECKED BY	MPA	DATE	21/03/2014	
C	BYPASS ASSEMBLY REVISED	DPB	16/11/2017	TITLE MAT270 Horizontal Chassis Fan Coil Unit Matrix 2.0 / Matrix 3.0 - 250 DIA	DRAWING NO.		REV	PAGE	
B	Model sizes 604 and 605 have been changed to sizes 600 and 650	LWV	03/08/2015		GS0341		D	2 of 3	
A	VALVE ASSEMBLY REVISED.	PRB	27/01/2015						
REV	DESCRIPTION	INIT	DATE						

ALL DIMENSIONS IN mm

FRACTIONAL TOLERANCE:  $\pm 2\text{mm}$   
 ANGULAR TOLERANCE:  $\pm 1^\circ$

### LEFT HAND FAN COIL UNIT SHOWN

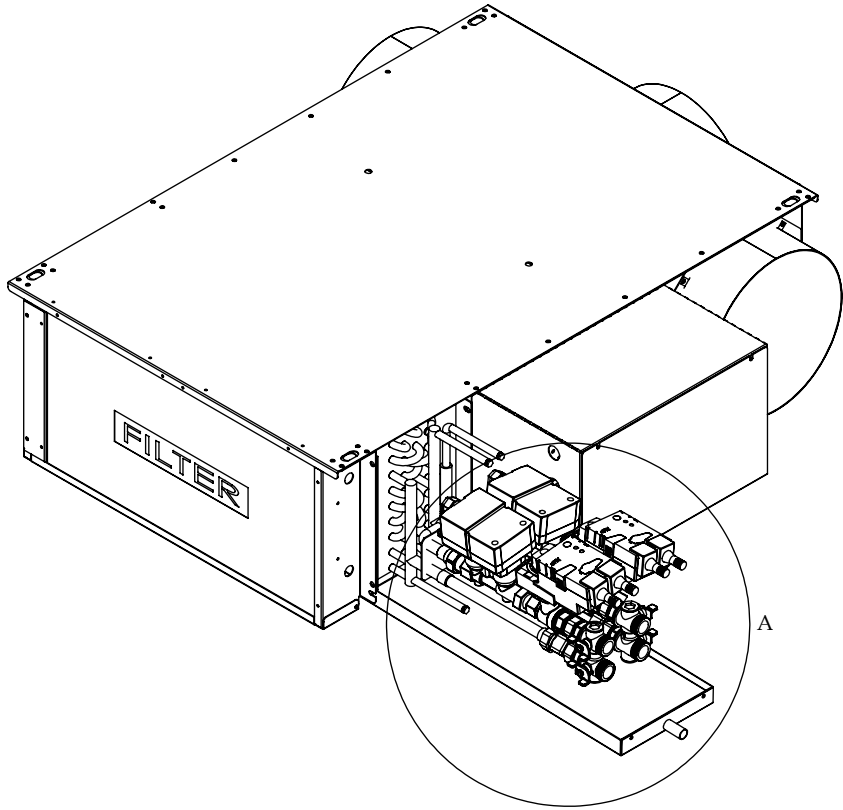

DETAIL A  
 SCALE 1:5

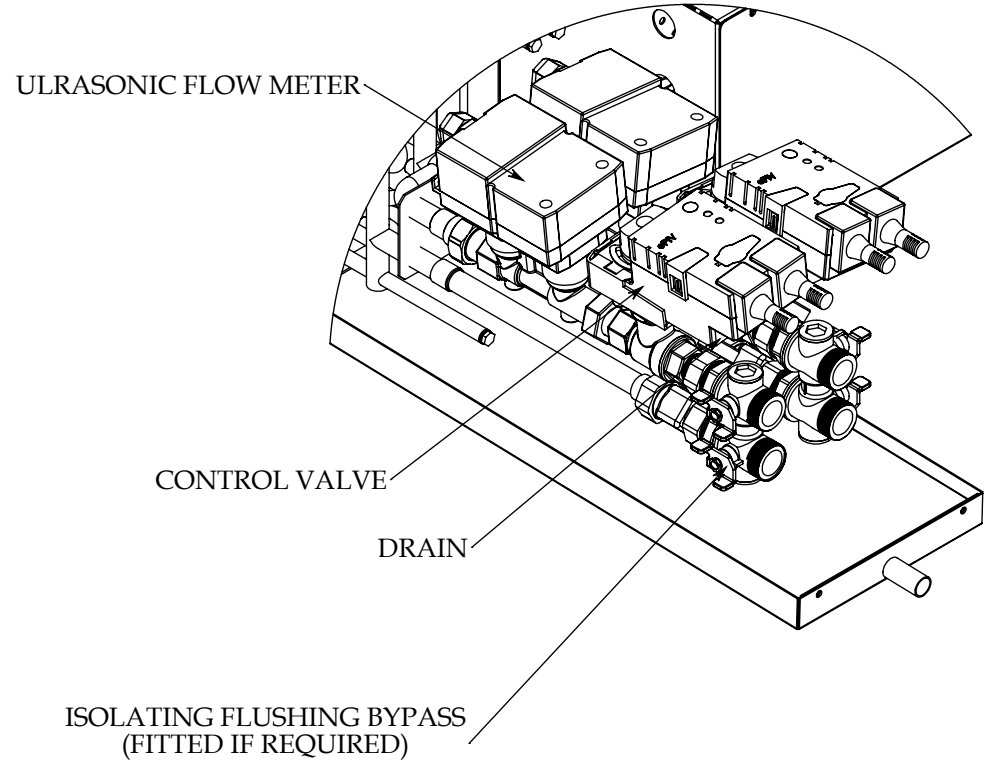

E											
D	Dimension added	AMB	16/01/2018		DRAWN BY	PRB	DATE	21/03/2014	SCALE	1:10	PAGE
C	BYPASS ASSEMBLY REVISED	DPB	16/11/2017		CHECKED BY	MPA	DATE	21/03/2014			
B	Model sizes 604 and 605 have been changed to sizes 600 and 650	LWV	03/08/2015	TITLE	DRAWING NO.			REV	3 of 3		
A	VALVE ASSEMBLY REVISED.	PRB	27/01/2015	MAT270 Horizontal Chassis Fan Coil Unit Matrix 2.0 / Matrix 3.0 - 250 DIA			GS0341		D		
REV	DESCRIPTION	INIT	DATE								